

# JOHN DOE™

## INSTALLATION AND OPERATING INSTRUCTIONS

KEEP ALL PLASTIC AND WIRE PARTS AWAY FROM CHILDREN

### PARTS:

1. MODULE
2. BACK FOOT
3. CLOTHING WITH HEAD AND FEET
4. UPPER POLE
5. LOWER POLE
6. FOOT REMOVAL "KEY"

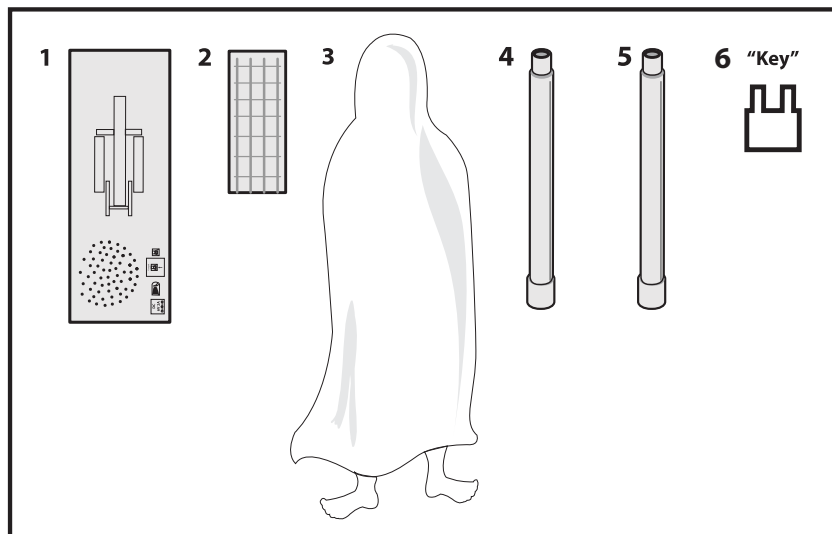

- 1.) Insert **BACK FOOT** into **MODULE** as shown in illustration 1a.  
(Matching A to A)

\* **NOTE:** Press to make sure each FOOT is flush with rectangular base. To remove FOOT, insert plastic "KEY" (included) into holes on bottom to release locks, twist and pull.

- 2.) Insert **UPPER POLE** through the bottom of **CLOTHING** and snap-lock into the base of neck. (Matching B to B)

- 3.) Insert **LOWER POLE** and snap-lock into the **MODULE**.  
(Matching C to C)

- 4.) Snap-lock **UPPER POLE** to **LOWER POLE**.

- 5.) Connect the wire from underneath the **CLOTHING** to the corresponding jack on the **MODULE**.

- 6.) Insert 4 AA batteries into the battery compartment located on the **MODULE** or connect DC adapter. (sold separately)

- 7.) Find a flat, stable area to place your John Doe. (make sure there are no obstructions to hinder the upper body movement) Extend feet and legs away from **MODULE** and spread out the sheet for a realistic look.

\* **NOTE:** Turn switch on top of **MODULE** to ON to operate in Timer/Sound mode (John Doe will function with 1.5 minute breaks between cycles - or, clap during 1.5 minute break to instantly start playing again). Leave switch in OFF position when not in use.

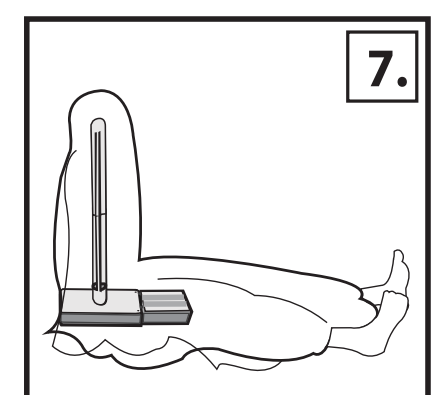
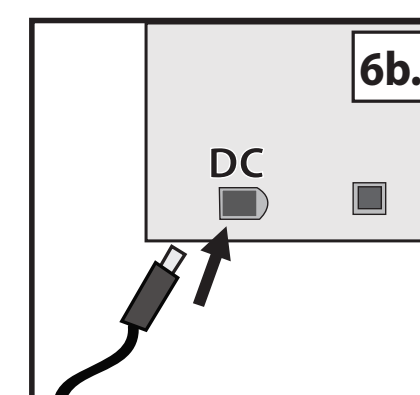
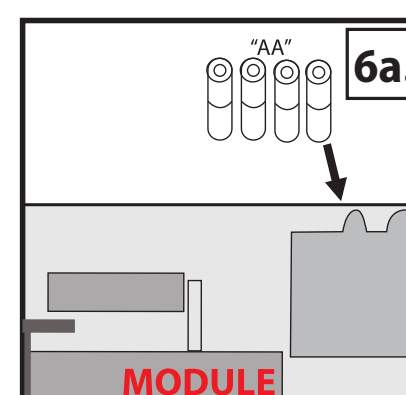
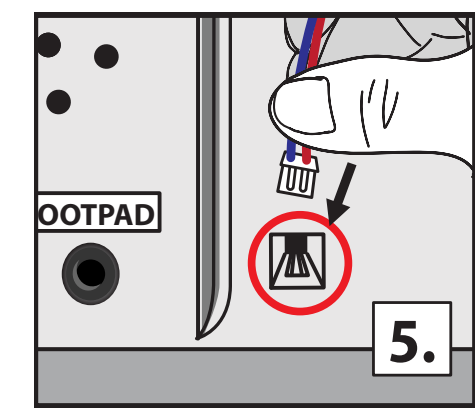
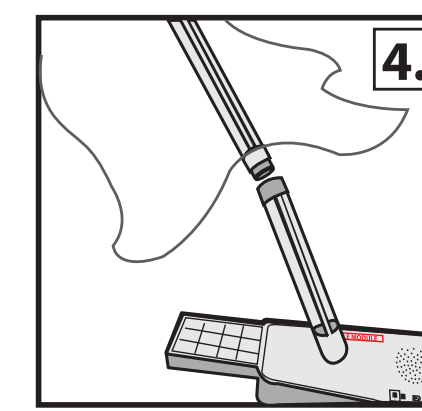
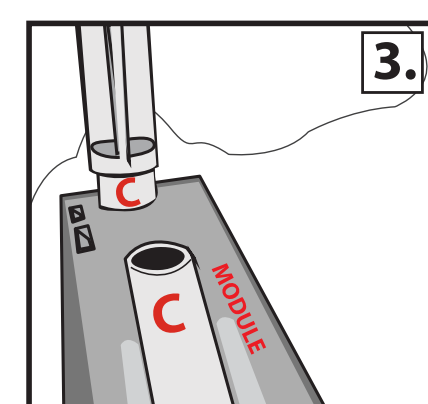
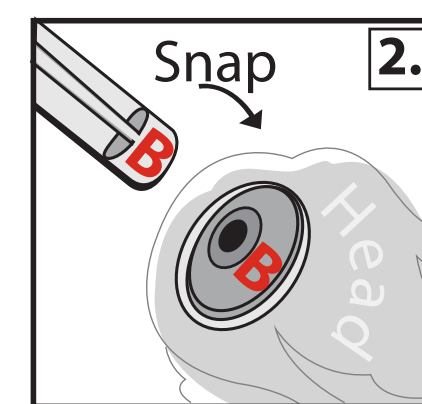
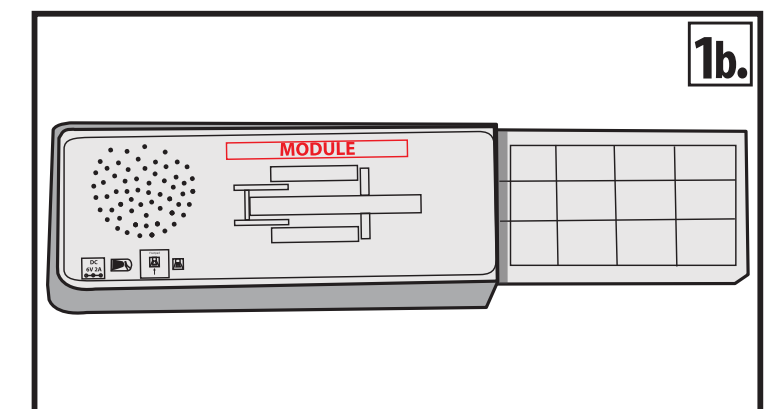
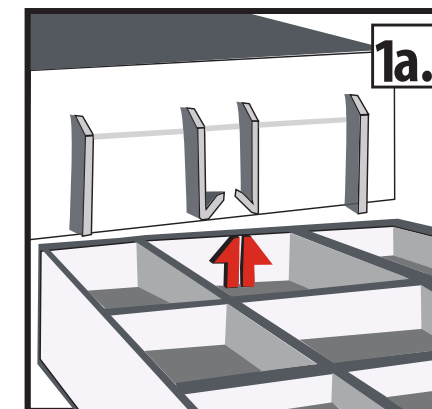

### Optional Footpad Setup

Follow steps #1 through 5 on initial installation first.

1. Connect the cable from the optional footpad to the jack labeled FOOTPAD located on the base.
2. Place the switch on the base into the 'FOOTPAD' position to enable FOOTPAD activation.
3. Step on FOOTPAD to activate the scary sequence. (go to instruction #6 to continue setup)

Do not use excessive force when inserting plug.

\*Footpads are sold separately and can be purchased at [www.tekkytoys.com](http://www.tekkytoys.com)

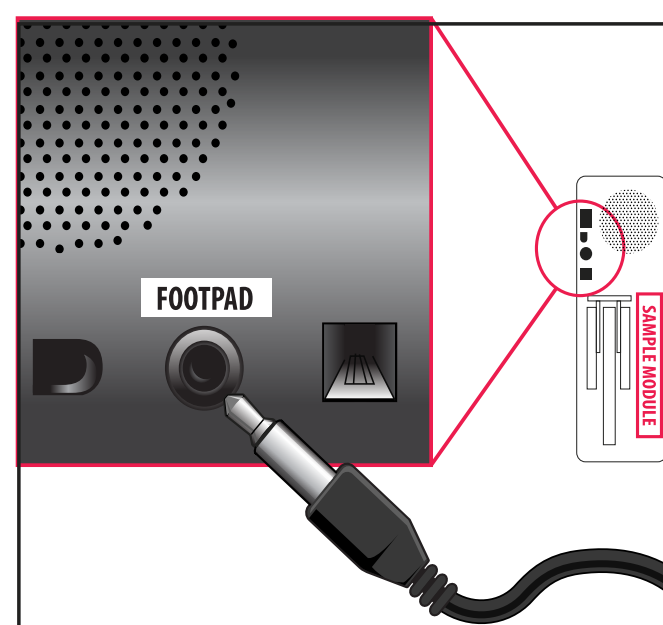

### MIT Multiple Trigger Set-up Instructions

Note:

Use in conjunction with any item that transmits MIT signal. Go to [www.tekkytoys.com](http://www.tekkytoys.com) for a list of items.

1. Plug MIT cable into MIT jacks on both items.
2. Turn switch on John Doe to footpad/MIT to activate.
3. Activate transmitting item to force activation of John Doe.

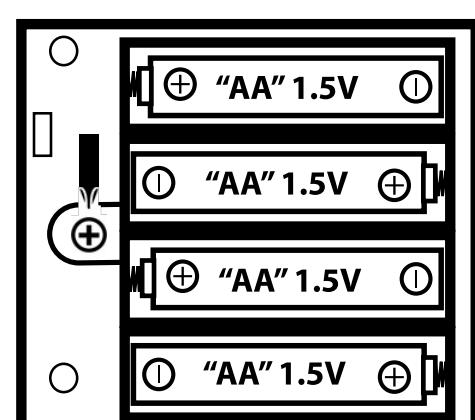

### BATTERY INSTRUCTIONS AND CAUTIONS:

- Use only the batteries recommended.
- Remove batteries when not in use.
- Do NOT use rechargeable batteries.
- Be sure to insert the batteries with the correct polarity +/-.
- Never mix different types of batteries: old and new, carbon-zinc, alkaline, nickel-cadmium.
- Always dispose of exhausted batteries properly.

**ADULT SUPERVISION IS RECOMMENDED WHEN CHANGING BATTERIES.**

**Warning!** This item is not a toy. For decoration only. Small parts, choking hazard. This product is intended for use by persons 15 years of age and older. Not intended for use by children ages 14 years and younger.

**WARNING**  
**DO NOT TURN ITEM ON UNTIL YOU HAVE COMPLETELY FINISHED ASSEMBLY.**  
**STAY CLEAR OF ITEM WHILE OPERATING.**  
**DO NOT PLACE ITEM ON UNEVEN GROUND.**  
**DO NOT PLACE WEIGHT ON ITEM WHILE IN OPERATION**



VISIT US AT [TEKKYTOYS.COM](http://TEKKYTOYS.COM)

Surface Washable Only.  
ALL NEW MATERIALS:  
PLASTIC, WIRE, POLYESTER, POLYESTER FIBRES,  
POLYURETHANE FOAM

Battery Powered:  
Requires 4 AA Batteries  
Optional DC Adapter Ready (6V 2A)

John Doe is a trademark of Tekky Toys.  
Copyright © 2011 Tekky Toys.  
All Rights Reserved. **MADE IN CHINA**



**DO NOT RETURN THIS ITEM TO THE STORE!**  
If experiencing technical difficulties, please go to [www.tekkytoys.com](http://www.tekkytoys.com) for assistance.

### SMART PHONE SCAN SETUP VIDEO

